



Cambridge International Examinations
Cambridge International General Certificate of Secondary Education

CANDIDATE
NAME

CENTRE
NUMBER

--	--	--	--	--

CANDIDATE
NUMBER

--	--	--	--



CO-ORDINATED SCIENCES

0654/23

Paper 2 (Core)

May/June 2016

2 hours

Candidates answer on the Question Paper.

No Additional Materials are required.

READ THESE INSTRUCTIONS FIRST

Write your Centre number, candidate number and name on all the work you hand in.

Write in dark blue or black pen.

You may use an HB soft pencil for any diagrams or graphs.

Do not use staples, paper clips, glue or correction fluid.

DO NOT WRITE IN ANY BARCODES.

Answer **all** questions.

Electronic calculators may be used.

You may lose marks if you do not show your working or if you do not use appropriate units.

A copy of the Periodic Table is printed on page 32.

At the end of the examination, fasten all your work securely together.

The number of marks is given in brackets [] at the end of each question or part question.

This document consists of **30** printed pages and **2** blank pages.

1 Aluminium foil is made when aluminium is rolled into thin sheets.

Aluminium foil is used to make food containers and fizzy-drink cans.

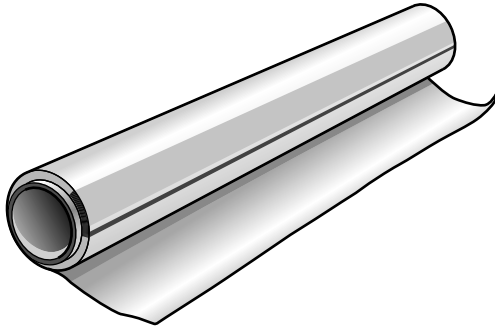

roll of aluminium foil



food container

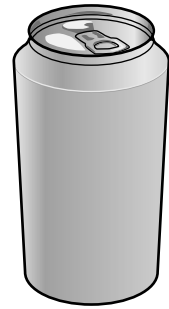

fizzy-drink can

(a) (i) State the property of aluminium that allows it to be rolled into thin sheets.

.....[1]

(ii) Many types of food and drink are acidic.

State the property of aluminium that makes it suitable for making food containers and fizzy-drink cans.

.....[1]

(b) Aluminium used to make fizzy-drink cans contains small amounts of other metals.

As well as the liquid, the fizzy-drink can contains gas under pressure.

(i) State the word used for a mixture of metals.

.....[1]

(ii) Suggest a reason why aluminium, containing small amounts of other metals, rather than pure aluminium, is used for fizzy-drink cans.

.....
.....
.....[2]

(c) Fig. 1.1 shows the process that is used to extract aluminium from aluminium oxide.

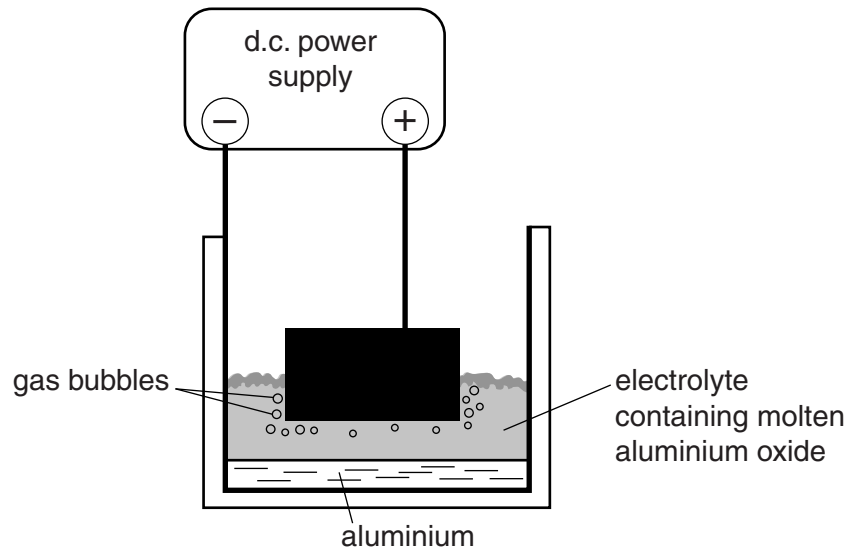

Fig. 1.1

(i) Name the process shown in Fig. 1.1.

.....

[1]

(ii) Label the cathode on Fig. 1.1.

[1]

(iii) State the element that is contained in the gas bubbles shown in Fig. 1.1.

.....[1]

(d) Aluminium oxide contains aluminium ions and oxide ions.

(i) State, in terms of electrons, how a metal atom is converted into an ion.

.....

.....[1]

(ii) In aluminium oxide, two aluminium ions are present for every three oxide ions.

State the chemical formula of aluminium oxide.

.....[1]

2 Fig. 2.1 shows some blood, as seen through a microscope.

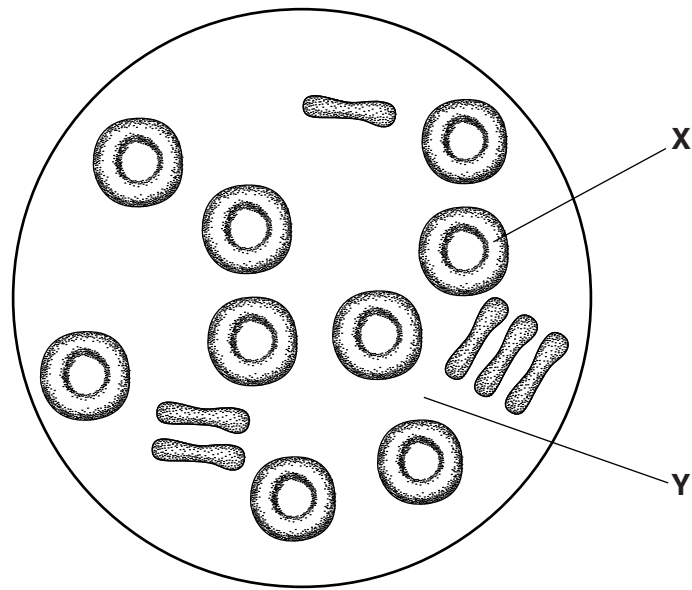

Fig. 2.1

(a) (i) Name the parts of the blood labelled X and Y.

X

Y

[2]

(ii) State the function of the part labelled X.

.....

.....[1]

(iii) Name **two** other components of the blood not shown in Fig. 2.1.

1

2

[2]

- (b) Fig. 2.2 shows a possible route that the blood might take, in travelling from the vena cava to one of the kidneys.

Complete the route by filling in the blanks in the boxes to show the name of a blood vessel or a chamber of the heart.

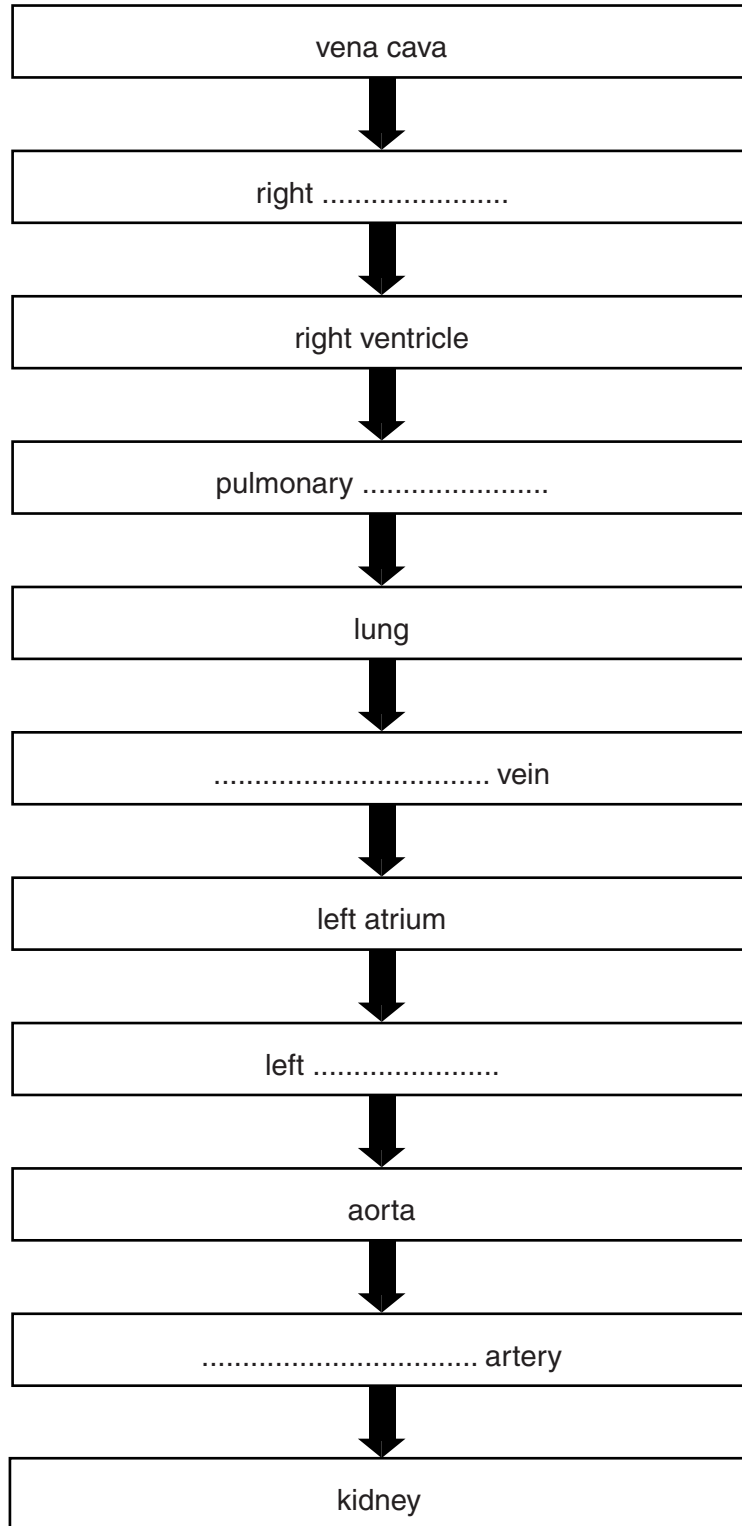

Fig. 2.2

[5]

3 (a) Some oil leaks from an oil tanker. It forms a very thin layer of oil on the surface of the seawater.

The density of the oil is 880 kg/m^3 .

The density of seawater is 1025 kg/m^3 .

Why does the oil float on top of the seawater?

.....
[1]

(b) Fig. 3.1 represents a water wave on the surface of the sea.

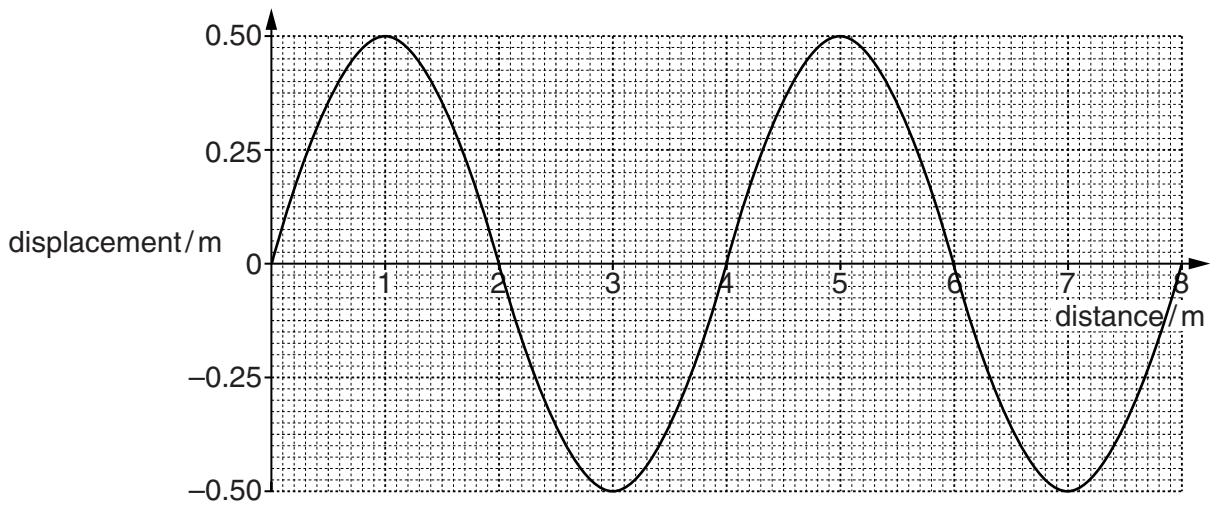

Fig. 3.1

(i) Determine the amplitude of the wave.

..... m [1]

(ii) Determine the wavelength of the wave.

..... m [1]

(iii) Two waves pass a fixed point in the sea over a period of 20 seconds.

Calculate the frequency of the waves.

frequency = Hz [1]

(c) The oil tanker is carrying crude oil. Crude oil is a non-renewable energy resource.

Other energy resources are shown in Table 3.1.

Table 3.1

	non-renewable	renewable
coal		
geothermal energy		
hydroelectricity		
natural gas		
solar		
energy from ocean waves		
tidal energy		

(i) Identify **two** non-renewable energy resources by placing a tick (✓) in the non-renewable column. [1]

(ii) Identify **two** renewable energy resources by placing a tick (✓) in the renewable column. [1]

(d) The depth of the sea below the oil tanker is determined by sending out pulses of ultrasound waves through the water. The ultrasound pulses reflect off the sea bed and the echoes are detected on the oil tanker.

Humans cannot hear ultrasound waves.

(i) State the maximum audible frequency for a human.

..... Hz [1]

(ii) State the minimum audible frequency for a human.

..... Hz [1]

- (iii) The echo of an ultrasound wave emitted by the oil tanker is detected 1.2 seconds later. The speed of ultrasound waves in water is 1500 m/s.

Calculate the depth of the sea below the oil tanker.

State the formula you use and show your working.

formula

working

distance = m [2]

4 In the African savannah (grassland), zebras feed on grass. They are preyed on by carnivores, such as lions. The lions have fleas in their fur. The fleas feed on the lions' blood.

(a) Construct a food chain containing four organisms, based on this description.

[2]

(b) In the savannah, state the term that describes

(i) grasses and other plants,

.....[1]

(ii) zebras **and** lions,

.....[1]

(iii) zebras, but **not** lions.

.....[1]

(c) In ecosystems such as the savannah, carbon atoms circulate in the carbon cycle.

Name a carbon compound that is

(i) absorbed by grasses,

.....[1]

(ii) transferred from zebras to lions,

.....[1]

(iii) released by lions into the atmosphere.

.....[1]

- 5 (a) Fig. 5.1 shows two headlamps in a car. The headlamps are connected in parallel with the battery. A switch and a fuse are also connected in the circuit.

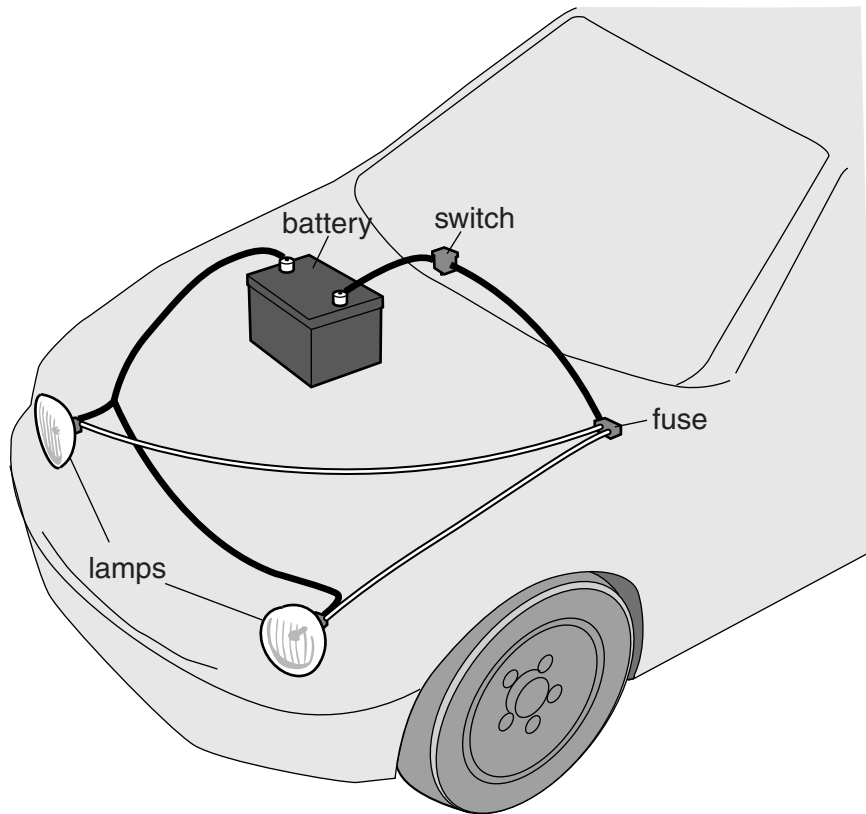

Fig. 5.1

Draw the circuit diagram for the car headlamps, shown in Fig. 5.1, using circuit symbols.

[2]

(b) When the headlamps are switched on, visible light is emitted.

Fig. 5.2 shows part of the electromagnetic spectrum. Visible light is part of the electromagnetic spectrum.

On Fig. 5.2, write *visible light* in the correct place.

[1]

gamma radiation		ultraviolet		infra-red		radio waves
-----------------	--	-------------	--	-----------	--	-------------

Fig. 5.2

(c) A small panel of the bodywork of the car is painted using an electrostatic paint spray gun.

The paint droplets leave the spray gun with a positive electric charge.

The bodywork panel is given a negative electric charge.

This is shown in Fig. 5.3.

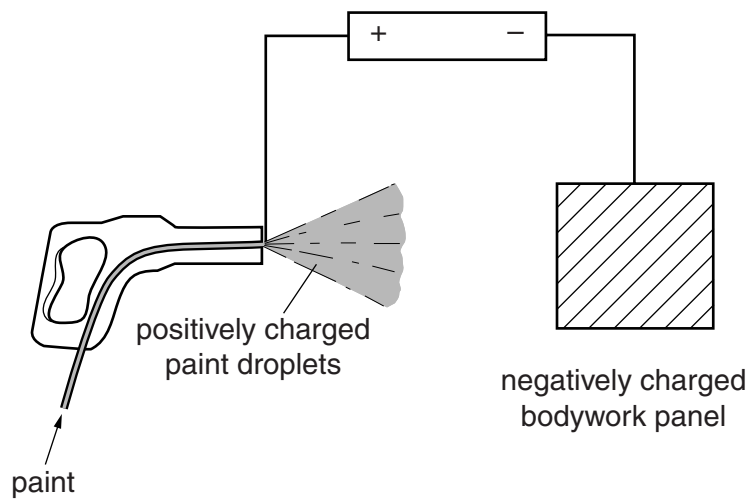

Fig. 5.3

Explain why this method ensures that the paint reaches the panel.

.....

.....[1]

(d) Fig. 5.4 shows the car travelling across a bridge made from concrete sections. There are gaps between each section, which are filled with a flexible material, such as rubber.

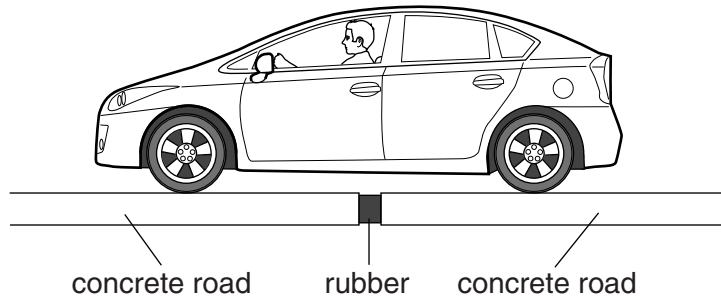

Fig. 5.4

Why are the gaps filled with a flexible material?

.....
.....
.....[2]

(e) The driver of the car sees a bus in his mirror, as shown on Fig. 5.5.

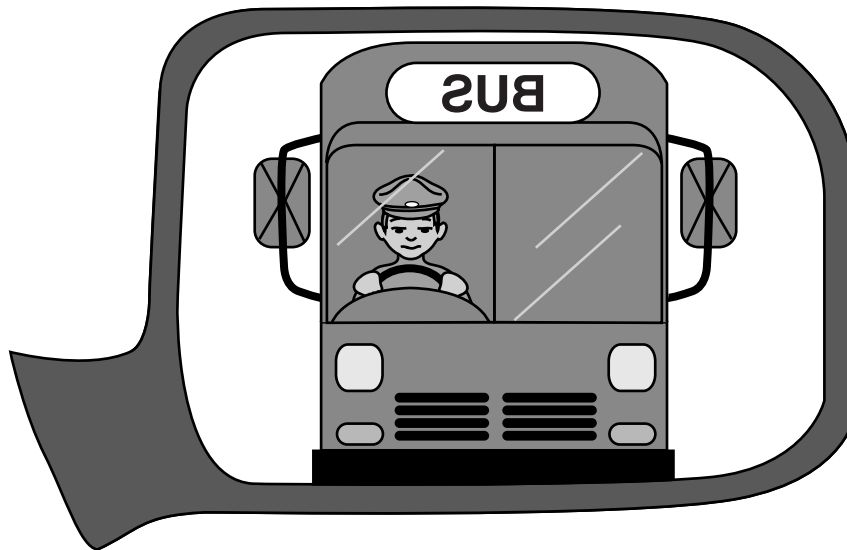

Fig. 5.5

Apart from any changes in size, describe **two** characteristics of the image that the driver sees.

1
2 [2]

6 (a) The inheritance of sex in humans depends on the sex chromosomes.

State the sex chromosomes present in

(i) a body cell of a female,

.....[1]

(ii) an egg cell,

.....[1]

(iii) a body cell of a male,

.....[1]

(iv) a sperm cell.

.....[1]

(b) State the name for a fertilised egg cell.

.....[1]

(c) Fig. 6.1 shows the female reproductive system and associated structures, shown in cross section.

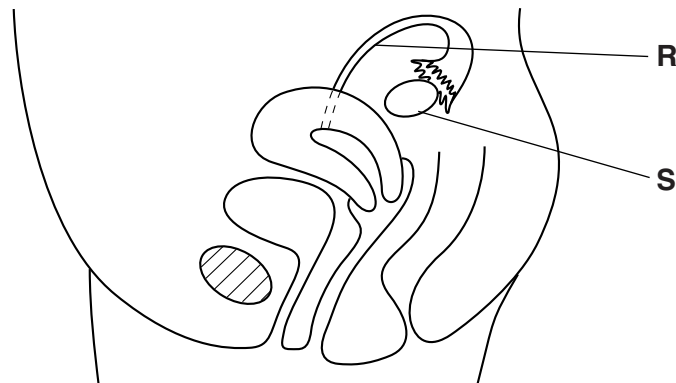

Fig. 6.1

(i) On Fig. 6.1, label with the letter **P**, the place where fertilisation occurs.

On Fig. 6.1, label with the letter **Q**, the place where the ball of cells resulting from a fertilised egg cell becomes implanted for further development. [2]

(ii) Name the structures labelled **R** and **S**.

R

S

[2]

(iii) State **one** function of the part labelled **S**.

.....

.....[1]

- 7 (a) Manganese dioxide, a black powder, is added to an aqueous solution of a compound, **J**.
This causes compound **J** to decompose and release a gas that relights a glowing splint.

Name this gas.

.....[1]

- (b) Fig. 7.1 shows apparatus and materials a student uses to investigate the speed of the reaction described in (a).

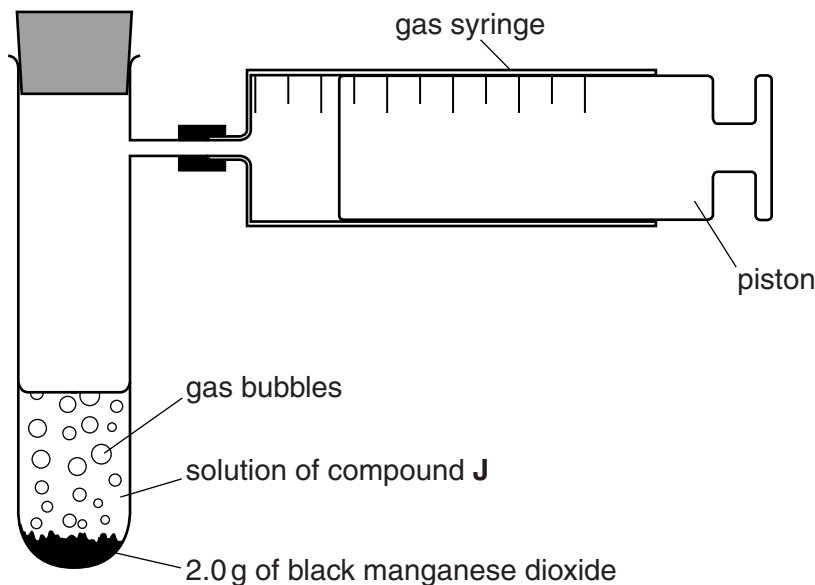

Fig. 7.1

The student measures the time, in seconds, taken to collect 100 cm³ of gas.

She then finds the speed of reaction using the equation shown.

$$\text{speed of reaction} = \frac{100}{\text{time in seconds}} \text{ cm}^3/\text{s}$$

- (i) Calculate the speed of reaction if the time taken to produce 100 cm³ of gas is 40 seconds.

speed of reaction = cm³/s [1]

- (ii) Suggest **one** change the student can make to her experiment that decreases the time taken to collect 100 cm³ of gas.

.....
.....[1]

- (iii) Manganese dioxide is a catalyst for the decomposition of compound J. The student uses 2.0g of manganese dioxide in her experiment.

State the mass of manganese dioxide that remains at the end of the reaction. Explain your answer.

mass of manganese dioxide remaining g

explanation

.....

.....

[2]

- (iv) Suggest **two** facts about manganese dioxide that would show that manganese is a typical transition metal.

1

.....

2

.....

[2]

- 8 Fig. 8.1 shows the inside of a refrigerator.

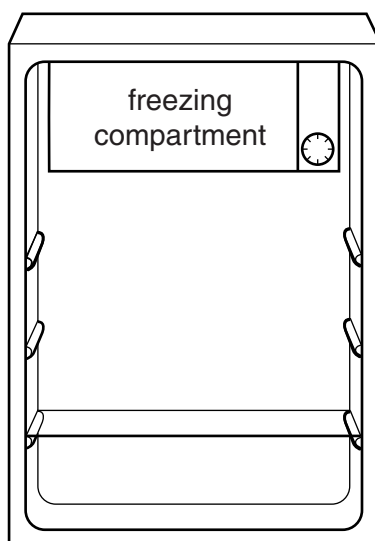

Fig. 8.1

- (a) (i) The air inside the refrigerator is cooled.

On Fig. 8.1, draw **one** straight arrow to show the movement of the air cooled by the freezing compartment. [1]

- (ii) State the name of this heat transfer process.

.....[1]

- (b) In the freezing compartment of the refrigerator, there is an ice tray with a volume of 300 cm^3 .

The tray is completely filled with ice.

The density of ice is 0.92 g/cm^3 .

Calculate the mass of the ice in the tray.

State the formula you use and show your working.

formula

working

mass =g [2]

- (c) The ice has been made by freezing some water.

Fig. 8.2 shows the arrangement of the particles in a liquid and in a solid.

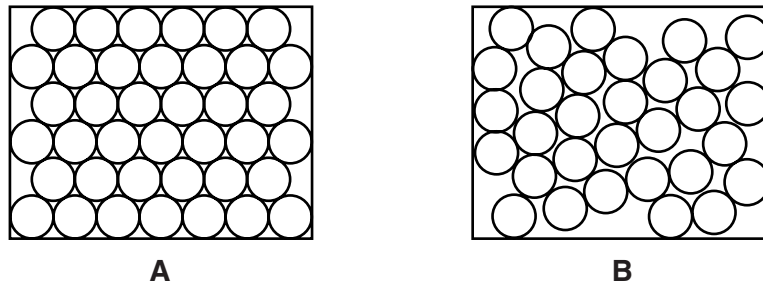

Fig. 8.2

Use the letters **A** or **B** from Fig. 8.2 to fill in the blank and complete the statement to explain your choice.

Diagram shows a solid because the particles

 [2]

- (d) There is a lamp inside the refrigerator. The supply voltage is 220V and the current through the lamp is 0.04 A.

- (i) Show that the resistance of the lamp is 5500 Ω.

State the formula you use and show your working.

formula

working

[2]

- (ii) Two lamps identical to the lamp in (d)(i) are connected in parallel.

The combined resistance of the two lamps is one of the following values.

- 2750 Ω 5500 Ω 11 000 Ω 22 000 Ω

Circle the correct value for the combined resistance. Explain your answer.

.....
 [1]

(e) Food kept in a refrigerator stays fresh for longer.

Another way to keep food fresh is to treat it with ionising radiation.

(i) Describe what is meant by the term *ionising radiation*.

.....
.....[1]

(ii) Name **one** type of ionising radiation.

.....[1]

(iii) State **one** danger of ionising radiation to the human body.

.....[1]

- 9 Table 9.1 shows information of some of the elements found in the same period of the Periodic Table.

Table 9.1

Group	IV	V	VI	VII	VIII
element symbol	Si	P	S	Cl	Ar
proton number	14	15	16	17	18
melting point / °C	1687	44	115	-102	-189

- (a) (i) State which period of the Periodic Table contains the elements shown in Table 9.1.
[1]
- (ii) Name the most reactive metal that is in the same period as the elements in Table 9.1.
[1]
- (iii) Explain the meaning of the following statement.
Silicon has a proton number of 14.

[1]
- (iv) State the number of electrons in a phosphorus atom.
 number of electrons [1]
- (v) Explain why a phosphorus atom is electrically neutral (neither positive nor negative).

[2]
- (vi) Describe the general trend in the melting points of the elements in Table 9.1.

[1]

(b) Argon is in Group VIII of the Periodic Table.

(i) State the name of the family of elements in Group VIII.

.....[1]

(ii) Fig. 9.1 shows caesium stored in a sealed glass container. Caesium is a reactive metal.

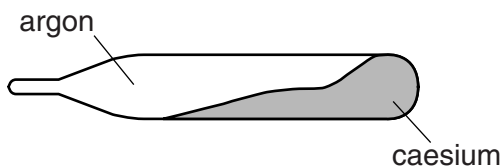

Fig. 9.1

Argon is also present in the container.

Why is argon used to fill the rest of the container rather than air?

.....
.....
.....[2]

(c) Chlorine is in Group VII of the Periodic Table.

(i) State why a colourless solution of sodium iodide becomes dark brown when it reacts with chlorine.

.....
.....[1]

(ii) Explain why chlorine is used to treat water that is supplied for drinking.

.....
.....
.....[2]

- 10 A student pinned a young bean plant to a cork board. The plant was on its side with light shining on it from above, as shown in Fig. 10.1.

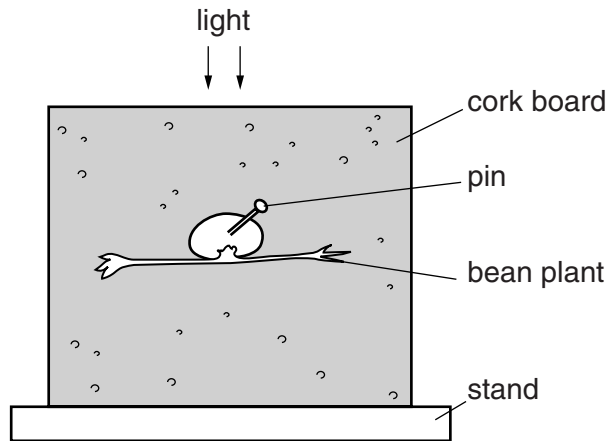

Fig. 10.1

Fig. 10.2 shows the appearance of the plant after two days.

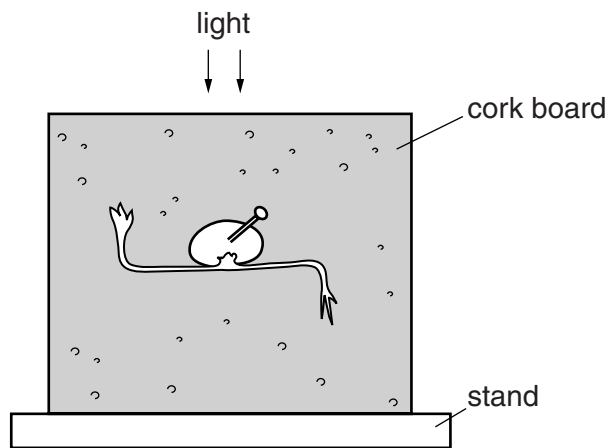

Fig. 10.2

- (a) State **two** characteristics of living organisms that cause the change in the appearance of the bean plant.

1

2

[2]

(b) The student concluded that his experiment showed that the plant stem responds to light by growing towards it.

(i) State the name for the type of response where a plant grows towards the light.

.....[1]

(ii) The student's experiment does **not** justify his conclusion. Explain why not.

.....
.....
.....[2]

(iii) Explain why growing towards the light increases the survival chances of a plant.

.....
.....[1]

- 11 (a) An athlete is training for a race. She runs along a race track. She accelerates from rest at a constant rate for 20 seconds and reaches a maximum speed of 6 m/s.

She continues at this speed for another 20 seconds.

During the next 5 seconds she slows down steadily and stops.

- (i) On the grid below draw a speed/time graph to show the motion of the athlete.

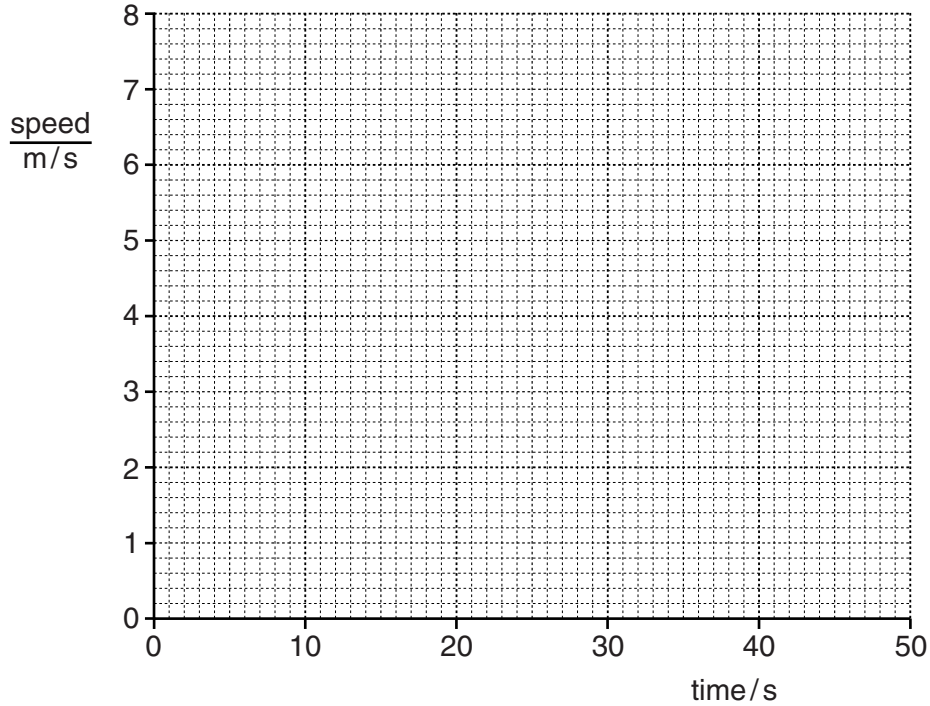

[3]

- (ii) Complete the sentence below, choosing the correct forms of energy.

As the athlete runs, the energy in the food she has eaten changes to energy and thermal energy.

[2]

(b) Fig. 11.1 shows another athlete running a race.

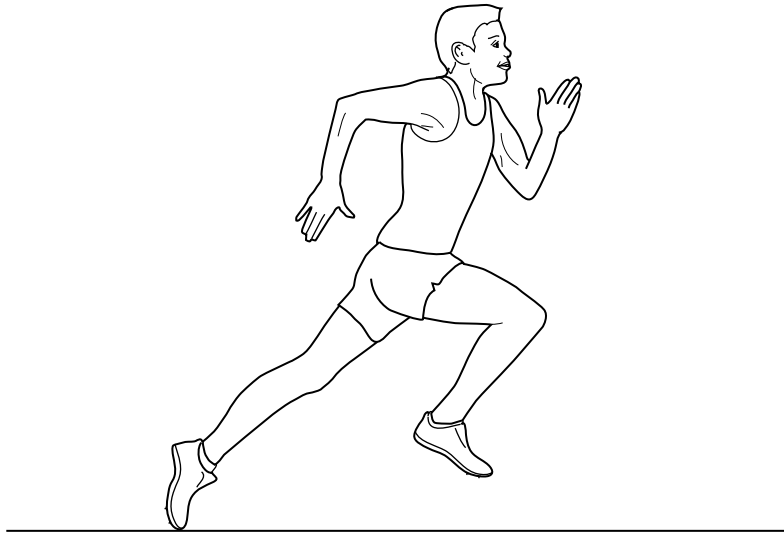

Fig. 11.1

Two forces acting on the athlete are his weight **E** and air resistance **F**, which slows the athlete.

Draw arrows on Fig. 11.1 to show the directions of these two forces. Label each force clearly using the letters **E** and **F**. [2]

- (c) A spectator is watching the race. He is standing behind other spectators and cannot see the race directly. He uses a periscope to see the race more clearly.

Fig. 11.2 shows the path of a ray of light passing through the periscope.

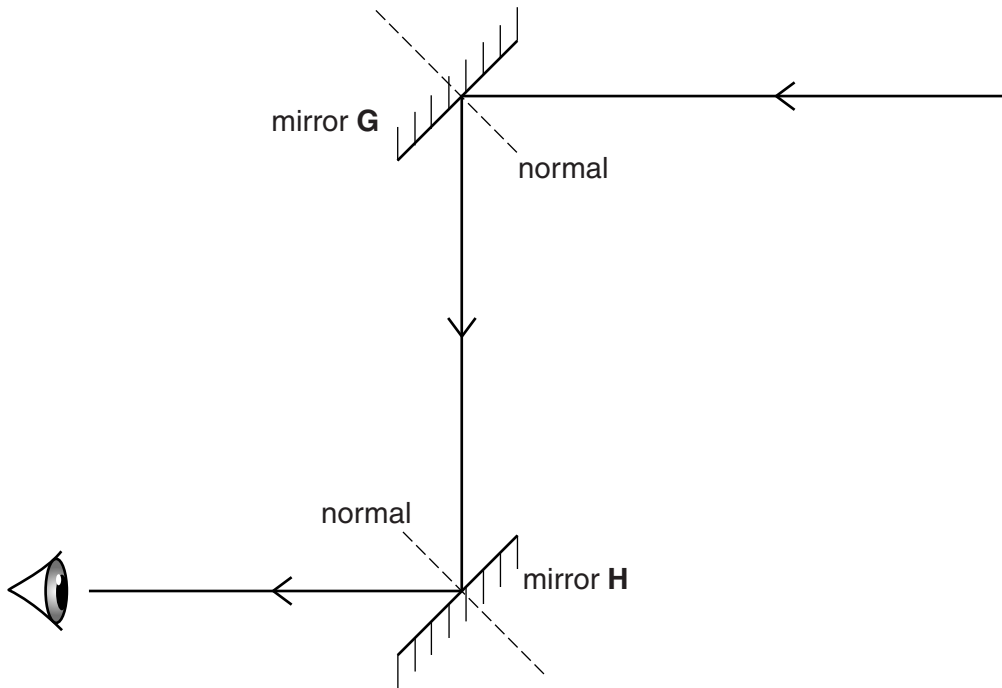

Fig. 11.2

- (i) On Fig. 11.2, use the letter **i** to indicate the angle of incidence of the ray striking mirror **G**. [1]

- (ii) The angle of incidence of the ray striking mirror **G** is 45° .

State the angle of reflection. Explain your answer.

angle of reflection = $^\circ$

explanation

.....[2]

12 (a) Petroleum is a fossil fuel.

(i) Name **one** other fossil fuel.

.....[1]

(ii) In the right hand column of Table 12.1 write a tick (✓) if the sentence about petroleum is correct or a cross (✗) if it is incorrect.

Table 12.1

It is a single compound made of hydrogen and carbon.	
It is extracted from the Earth's crust.	
It can be used as a fuel for cars.	
It has taken millions of years to form.	

[2]

(b) Fig. 12.1 shows two processes which are carried out at an oil refinery.

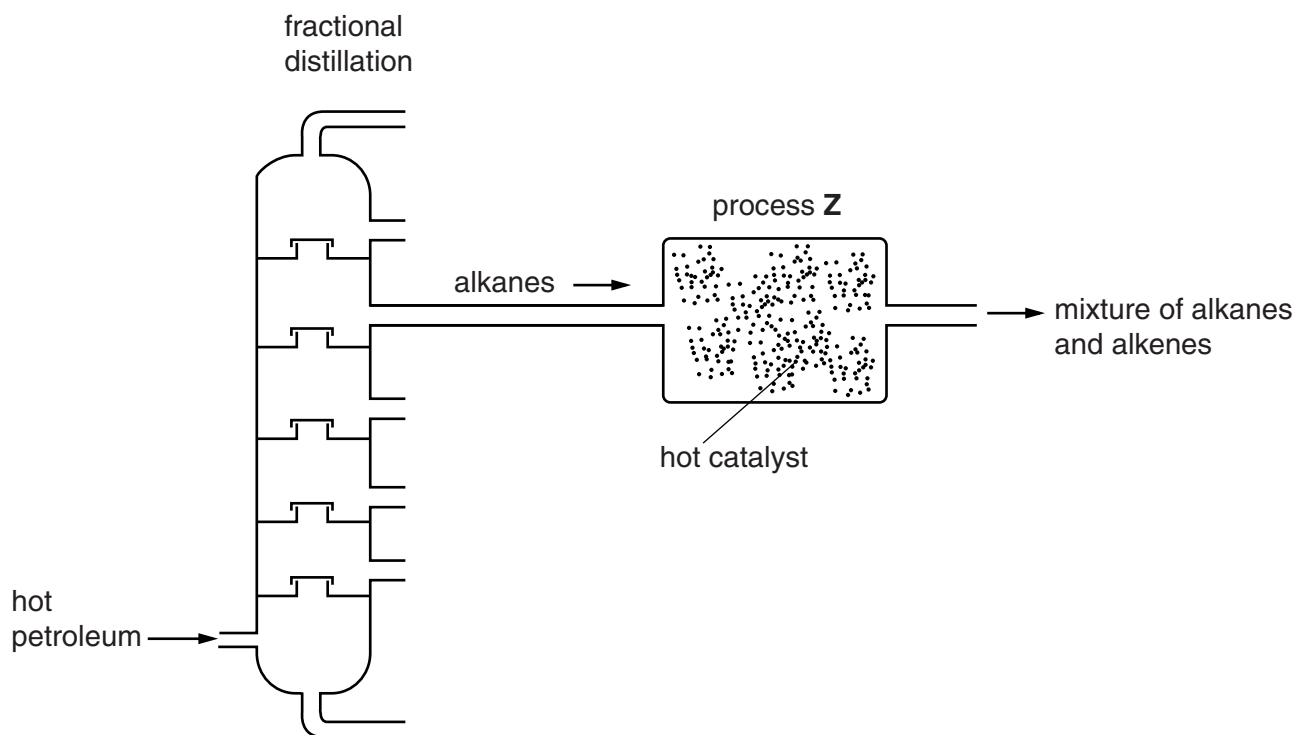

Fig. 12.1

- (i) Explain why fractional distillation is used to process petroleum.

.....

[2]

- (ii) State whether the changes that take place during fractional distillation are physical changes or chemical changes. Explain your answer.

type of change

explanation

.....
[2]

- (c) Process **Z**, shown in Fig. 12.1, is used to produce alkenes from alkanes.

- (i) Name process **Z**.

.....[1]

- (ii) State which **one** of the four molecules, **L**, **M**, **N** and **O**, in Fig. 12.2 is an alkene.

Give a reason for your answer.

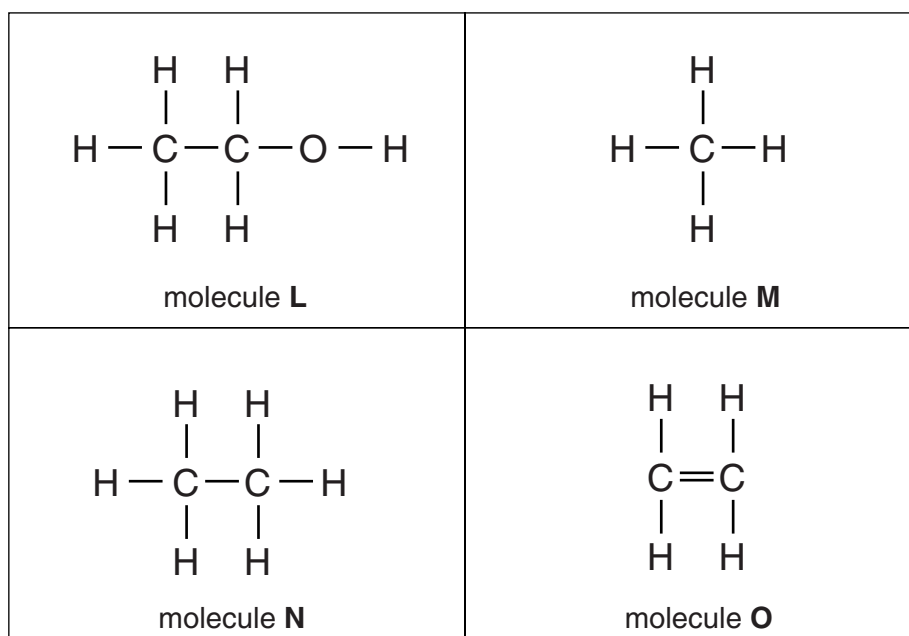

Fig. 12.2

molecule

reason

.....[2]

13 Scientists have investigated the possibility of humans living on the planet Mars. To live on Mars people would need to grow plants on the planet.

(a) Explain why humans would be dependent on these plants.

.....
[1]

(b) Table 13.1 shows some of the conditions on Mars, compared to Earth.

Table 13.1

	Earth	Mars
distance from the Sun/millions of km	149.6	227.9
mean surface temperature/°C	14	-55
carbon dioxide in the atmosphere/%	0.03	95
availability of water	large amounts	traces

(i) Explain why the distance of the planet from the Sun would be important for plants growing on Mars.

.....
[1]

(ii) State **one** way in which water is needed to keep plants alive.

.....[1]

(iii) State whether the carbon dioxide concentration of the atmosphere on Mars (compared to that on Earth) will increase plant growth. Explain your answer.

.....

[1]

- (iv) If large numbers of plants were grown on Mars for a long period of time, predict how this might change the planet's atmosphere. Explain your answer.

change

.....

explanation

.....

.....

[2]

The Periodic Table of Elements

		Group																
I	II	III	IV	V	VI	VII	VIII											
3 Li lithium 7	4 Be beryllium 9	1 H hydrogen 1	5 B boron 11	6 C carbon 12	7 N nitrogen 14	8 O oxygen 16	9 F fluorine 19	10 Ne neon 20										
11 Na sodium 23	12 Mg magnesium 24	13 Al aluminium 27	14 Si silicon 28	15 P phosphorus 31	16 S sulfur 32	17 Cl chlorine 35.5	18 Ar argon 40											
19 K potassium 39	20 Ca calcium 40	21 Sc scandium 45	22 Ti titanium 48	23 V vanadium 51	24 Cr chromium 52	25 Mn manganese 55	26 Fe iron 56	27 Co cobalt 59	28 Ni nickel 59	29 Cu copper 64	30 Zn zinc 65	31 Ga gallium 70	32 Ge germanium 73	33 As arsenic 75	34 Se selenium 79	35 Br bromine 80	36 Kr krypton 84	
37 Rb rubidium 85	38 Sr strontium 88	39 Y yttrium 89	40 Zr zirconium 91	41 Nb niobium 93	42 Mo molybdenum 96	43 Tc technetium —	44 Ru ruthenium 101	45 Rh rhodium 103	46 Pd palladium 106	47 Ag silver 108	48 Cd cadmium 112	49 In indium 115	50 Sn tin 119	51 Sb antimony 122	52 Te tellurium 128	53 I iodine 127	54 Xe xenon 131	
55 Cs caesium 133	56 Ba barium 137	57–71 lanthanoids	72 Hf hafnium 178	73 Ta tantalum 181	74 W tungsten 184	75 Re rhenium 186	76 Os osmium 190	77 Ir iridium 192	78 Pt platinum 195	79 Au gold 197	80 Hg mercury 201	81 Tl thallium 204	82 Pb lead 207	83 Bi bismuth 209	84 Po polonium —	85 At astatine —	86 Rn radon —	
87 Fr francium —	88 Ra radium —	89–103 actinoids	104 Rf rutherfordium —	105 Db dubnium —	106 Sg seaborgium —	107 Bh bohrium —	108 Hs hassium —	109 Mt meitnerium —	110 Ds darmstadtium —	111 Rg roentgenium —	112 Cn copernicium —	114 Fl flerovium —	116 Lv livermorium —	—	—	—	—	
		57 La lanthanum 139	58 Ce cerium 140	59 Pr praseodymium 141	60 Nd neodymium 144	61 Pm promethium —	62 Sm samarium 150	63 Eu europium 152	64 Gd gadolinium 157	65 Tb terbium 159	66 Dy dysprosium 163	67 Ho holmium 165	68 Er erbium 167	69 Tm thulium 169	70 Yb ytterbium 173	71 Lu lutetium 175		
		89 Ac actinium —	90 Th thorium 232	91 Pa protactinium 231	92 U uranium 238	93 Np neptunium —	94 Pu plutonium —	95 Am americium —	96 Cm curium —	97 Bk berkelium —	98 Cf californium —	99 Es einsteinium —	100 Fm fermium —	101 Md mendelevium —	102 No nobelium —	103 Lr lawrencium —		

Key

atomic number
atomic symbol
name
relative atomic mass

lanthanoids

actinoids

The volume of one mole of any gas is 24 dm³ at room temperature and pressure (r.t.p.)